



Manual Issue Number R5, Date; May 2023

p034L1r5b.lwp

USER MANUAL

SRC SERIES THYRISTOR STACKS FOR RESISTIVE LOADS, 315-800A



IMPORTANT

This manual applies to stacks in the SRC range which are rated above 300A. Units of lower current rating may have different terminal number assignments from those shown in this manual

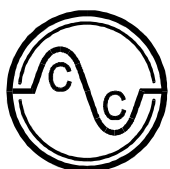

Caledon Controls Ltd

Tel +44 (0)1555 773355

Unit 2 Block 4, Castlehill Ind. Est., Carluke, Lanarkshire, Scotland, ML8 5UF
Website www.caledoncontrols.co.uk Email info@caledoncontrols.co.uk

REVISION HISTORY

R1	First issue April 2001	
R2	September 2002	Corrects errors in the fuse type table for 600A and 800A units. Adds improved instructions for removal and replacement of end contact fuse types
R3	November 2003	Details of new driver card shelf. Updated dimensional drawing
R4	May 2004	Corrected error in terminal function list; table page 13, B1, B2, B3 incorrectly assigned.
R5	May 2023	New photo on front.

Table of Contents

REVISION HISTORY	Page 2
CONTACTING US	Page 4
FEATURES	Page 5
GENERAL DESCRIPTION	Page 5
SRC 1000 Series	Page 5
SRC 2000 Series	Page 5
SRC 3000 Series	Page 5
Current Ratings and Approximate Dimensions (height x width x depth)	Page 6
ORDERING INFORMATION	Page 6
SPECIFICATIONS	Page 6
Physical	Page 6
Environmental	Page 6
Electrical	Page 6
Control Signal Inputs and Outputs	Page 7
Analogue input card	Page 7
LED Indicators	Page 7
Compliance with Standards	Page 7
European Low Voltage Directive	Page 7
Electromagnetic Compatibility	Page 7
SAFETY INFORMATION	Page 8
TABLE OF SEMICONDUCTOR FUSE TYPES	
– CHANGING THE FUSES	Page 8
Blade Contact Types	Page 8
End Contact Types	Page 8
INSTALLATION	Page 10
General Requirements	Page 10
Mounting	Page 11
Cover Removal and Replacement	Page 11
Typical Wiring Schematics	Page 12
Recommended Power Cable Sizes	Page 13
Power Cables and Access to the Load Terminals	Page 13
Signal and Auxiliary Connection Terminals	Page 14
Terminal Function List	Page 14
Auxiliary Line Connections	Page 15
Fan and Analogue Input Card Supply Connection	Page 15
Control Cables	Page 15
Logic Inputs	Page 15
Analogue Inputs	Page 16
Fuse Failure Indication and Output Signal	Page 17
BRIEF NOTES ON OPERATION	Page 17
Cover	Page 17
Demand Signal	Page 17
Logic Control Signal	Page 17
Analogue Control Signal	Page 17
Fuse Failure Indication	Page 18
FAULT FINDING	Page 19

CONTACTING US

Please feel free to contact us if you require further information or advice on the application, installation or maintenance of these units.

If in doubt - ask!

We can be contacted by telephone, e-mail, fax or letter. Contact information is on the front page of the manual. If you have a query regarding a specific unit, please let us know the model number and serial number of the unit when you contact us.

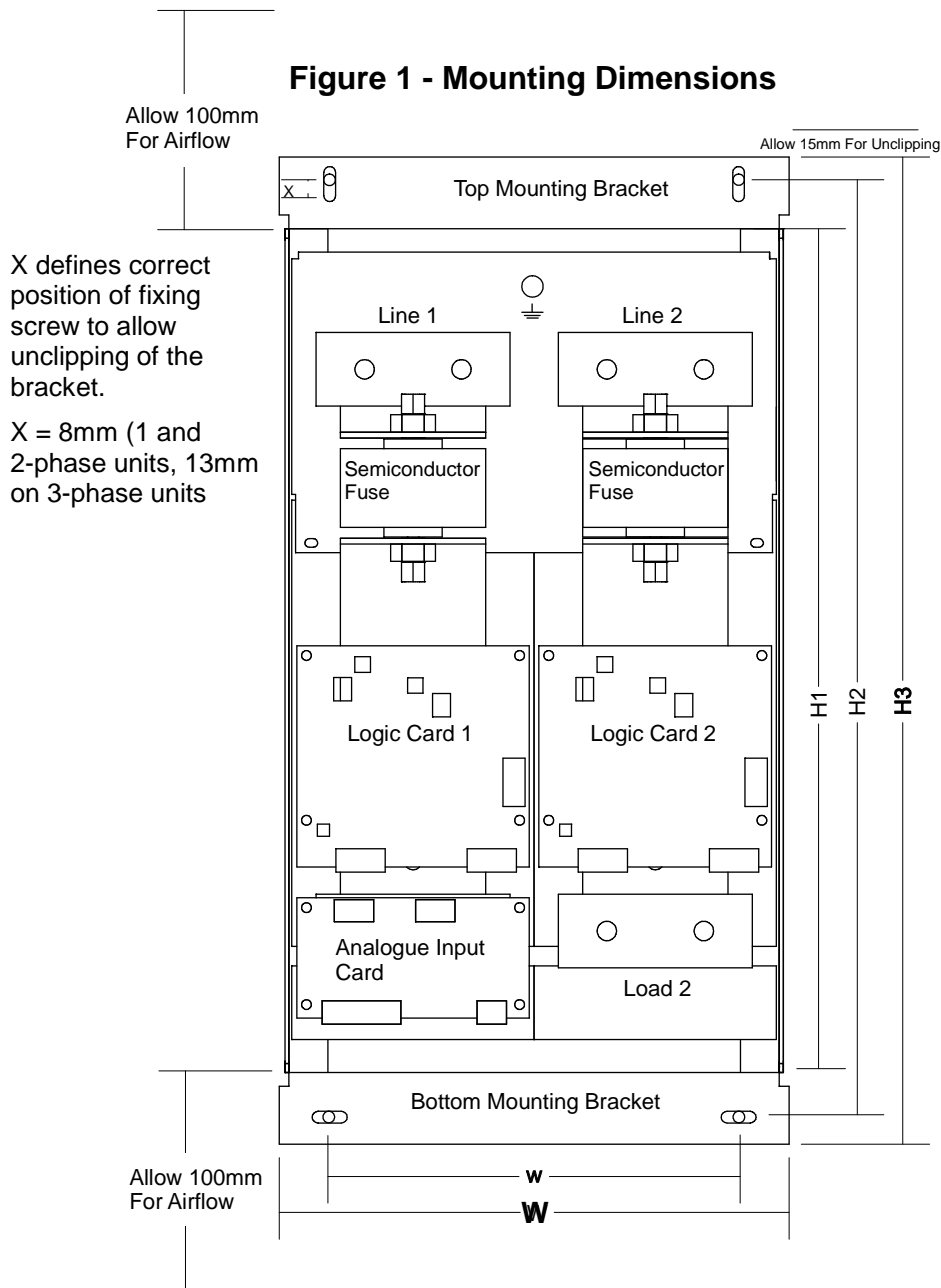

The drawing above shows the SRC2000 600 / 800A model. Dimensions of all models are as shown below

Model	Overall Width W	Fixing Centres w	Body Height H1	Fixing Centres H2	Height inc. Clamp H3	Depth
SRC1000	138mm	86mm	435mm	471mm	495mm	265mm
SRC2000	263mm	211mm	435mm	471mm	495mm	
SRC3000	390mm	336mm	435mm	477mm	513mm	

FEATURES

- **Space saving compact, slimline design**
- **Robust conservatively rated construction**
- **Long life ball bearing fans**
- **Built in EMC filters**
- **Built in semiconductor fuses**
- **Logic or analogue control input options**
- **Fuse / Phase failure alarm output**

GENERAL DESCRIPTION

This is a modern range of thyristor stacks, specifically designed for burst fire control of resistive loads in medium and high current heating applications for furnaces, ovens, dryers etc. These units use a proven MOSFET driver circuit, and feature closely controlled zero-voltage switch on, and low crossover commutation noise.

The standard input is a logic signal, but an optional analogue input driver card is available which accepts 0-5V, 1-5V, 0-10V (and 0-20mA, 4-20mA with 250 ohm burden resistor).

The stacks have generously sized heatsinks and power semiconductors to ensure long term reliability. The power connections are to stud terminals, which are reliable at elevated temperatures, and under conditions of temperature cycling.

The line to line EMC filter capacitors, ensure very low conducted emissions, and together with the MOV and snubber protection, contribute to very high immunity to conducted interference.

The top and bottom removable mounting clips help simplify installation and subsequent removal for maintenance if required. The covers enclose both power and signal connections to protect against accidental contact. The width of the units has been kept small to simplify side by side mounting in multi-zone applications.

SRC 1000 SERIES

Single phase units for higher current applications from 250A to 800A

SRC 2000 SERIES

These units feature two independent controllers, and may be used for two line control of a 3-phase 3-wire load (without neutral connection) either star or delta connected, or alternatively for two independent single phase loads. The slimline design minimises the installed space requirement, particularly useful in multi-zone applications.

SRC 3000 SERIES

A range of 3-phase units, which may be used to control 3 single phase loads, or a single 3-phase load, either 3-wire star or delta, or 4-wire star connected.

CURRENT RATINGS AND APPROXIMATE DIMENSIONS (HEIGHT X WIDTH X DEPTH)

Allow 100mm above and below the stack for ventilation, in addition to the height dimension in the table, and 15mm between units. The fixing clamps at top and bottom of the stack extend 40mm above and below the height dimensions in the table, but within the 100mm ventilation allowance (see figure 1).

Current Rating	SRC 1000 Dimensions and approximate weight	SRC 2000 Dimensions and approximate weight	SRC 3000 Dimensions and approximate weight
315A	435mm x 136mm x 265mm 8kg	435mm x 262mm x 265mm 15kg	435mm x 388mm x 265mm 23kg
400A	435mm x 136mm x 265mm	435mm x 262mm x 265mm	435mm x 388mm x 265mm
600A	435mm x 136mm x 265mm	435mm x 262mm x 265mm	435mm x 388mm x 265mm
800A	435mm x 136mm x 265mm 12kg	435mm x 262mm x 265mm 23kg	435mm x 388mm x 265mm 34kg

ORDERING INFORMATION

The stacks may be ordered using the order code shown below, or by description:-

Type	Current Rating	Voltage Rating	Fan Supply Voltage AC 50/60 Hz	Analogue Input Options

SRC1000, SRC2000, SRC3000

From table above

250V, 440V, 480V, 660V*

115V, 230V

See below

The standard stack is supplied with logic inputs. Optionally an analogue input card may be fitted, which converts analogue input signals to logic signals and provides 1 or 2 analogue inputs. On 3-phase models two cards may be fitted to provide 3 analogue inputs. Specify your requirements and the card(s) will be pre-wired by us to the logic inputs. This card also provides a relay which interfaces to the fuse failure transistor outputs to provide a volt free changeover contact suitable for use with higher voltages.

SPECIFICATIONS

PHYSICAL

Dimensions and approximate weights See table and figure 1

ENVIRONMENTAL

Ambient Operating Temperature	0-50°C (800A units 0-45°C) at rated current
Storage Temperature	-25°C to +70°C
Relative Humidity	0-95% non condensing
Pollution (IEC 60664)	Degree 2 (Only non conductive pollution is allowed. Temporary condensation may occur, but not normally while equipment is operating).
Elevation	Derate current rating 1% per 100 metres above 200 metres

ELECTRICAL

Rated Supply Voltage (Load) 250V, 440V, 480V, 660V* +10%, -25%

Rated Current	As ordered. Rated current is specified at 50°C ambient temperature except 800A unit (45°C)
Supply Frequency	50Hz or 60Hz \pm 8%
Rated Impulse Withstand Voltage	(IEC 60664) 4KV
Fan supply voltage	115 or 230V AC RMS, +10%, -15%

CONTROL SIGNAL INPUTS AND OUTPUTS

The standard unit accepts logic control inputs for each phase. These may be wired by the user to fire simultaneously, or may be wired independently. Also provided is an isolated transistor output for each phase, indicating phase presence / absence. These also may be wired together or independently. The optional analogue driver card accepts either one or two analogue inputs, and may be used to drive one or two independent single phase loads, or a single 3-phase load. This card also provides a single relay output, which may be driven by the phase detection transistor outputs to interface to higher voltage logic.

Logic input control signal	Max 30V input. Switching threshold >6V on, <2V off. Isolation between inputs on the same stack 1500V
Alarm output	A volt free transistor output is provided on each phase, which is normally on and turns off on loss of phase voltage or semiconductor fuse failure. Rating 24V DC, 250mA

ANALOGUE INPUT CARD

Supply voltage (match with fans)	115 or 230V AC RMS, +10%, -15%
Input signals	0-5V, 1-5V, 0-10V, 0-20mA, 4-20mA (use 250 burden resistor for mA inputs). Two inputs are available, not isolated from each other.
Output Signal	Volt free relay changeover contact indicates loss of phase voltage / fuse failure. Rated 250V, 0.5A

LED INDICATORS

Two LEDs are provided on each phase; one which indicates the presence of the line voltage, and thus serves as a fuse status indicator, and one which indicates when load current is being demanded. The analogue input card has an LED to indicate that it is powered.

Notes

All units are fitted with snubber capacitors, MOV transient over voltage protection, and emc filter capacitors.

* 660V units. Note that impulse withstand voltage is restricted to 4kV and emc filter capacitors are omitted. Consult us.

COMPLIANCE WITH STANDARDS

EUROPEAN LOW VOLTAGE DIRECTIVE

The stacks are designed to meet the requirements of international standards and are CE marked in compliance with the European Low Voltage Directive.

The following standards have been applied in whole or in part in the design of these units: EN 60947-1, EN61010-1, EN50178

ELECTROMAGNETIC COMPATIBILITY

The control circuits of the unit meet or exceed the requirements of EN 61000-6-2 and EN 50 081 part 2 (immunity and emissions for industrial environment). The thyristor drive circuitry is designed to minimise conducted emissions associated with the load current, and additional filtering will not normally be necessary. Application notes provide information on system design for compatibility.

SAFETY INFORMATION

These thyristor stacks must be earthed. The earthing arrangements must be able to carry the fault current associated with a short circuit of the main load circuit to the metalwork of the stack, until the protection device opens.

Thyristor stacks must never be used as a means of supply isolation, as even in the 'off' state lethal leakage currents will flow. An independent means of isolation, complying with local standards must always be fitted.

The clear polycarbonate cover provides protection against accidental contact with live parts, and must never be removed unless the main supply has been isolated elsewhere. Busbars and circuitry on the printed circuit boards under this cover carry the full line voltage.

Maintenance and installation work on these units should only be carried out by suitably qualified and trained personnel who have read and are familiar with the contents of this manual.

Additional information is provided under 'Installation – General Requirements'.

TABLE OF SEMICONDUCTOR FUSE TYPES – CHANGING THE FUSES

Checking or changing of any fuse must not be attempted unless both main and driver supplies are isolated. To do so is extremely dangerous, and may also cause damage to the stack.

See 'Cover removal and Replacement' for instructions on how to remove and replace the cover.

The semiconductor fuses listed in the table below may be used. Consult us before using other fuse types. One fuse is required per phase.

Fuses fitted with blades are used on the 315 and 400A units; those in the 600 and 800A units have end contacts.

Stack Current Rating	Nominal Fuse Current Rating	Fuse I ² t Rating (10 ³ A ² s)	Fuse Type (DIN 43 653 80mm fixing centres)	Alternative Fuse Type (N. American fixing centres)
315A Ferraz Bussman	450A	140 120	C 300 014 170M4113	X 300 032 170M3620
400A Ferraz Bussman	550A	280 230	E 300 016 170M4115	Z 300 034 170M3622
End Contact types				
600A Ferraz Bussman	900A	900 840	Q300 072 170M5415	
800A Ferraz Bussman	1100A	1,260 1,300	C300 083 170M6415	

BLADE CONTACT TYPES

The upper fuse support pillars are adjustable in slotted holes to cater for the different pitch of alternative fuses. If necessary slacken the M8 hex head fixing screws on the heatsink side of the mounting plate (See (8) in the drawing for end contact types), and adjust the pillar as required, then re-tighten.

Note that a serrated lockwasher is fitted behind the fuse on the upper studs. It is most important that this is not omitted, otherwise excessive torque may be transmitted to the stud when the fuse retaining nuts are tightened. The recommended tightening torque for these nuts is 15Nm

END CONTACT TYPES

It is imperative when loosening or tightening the nuts which secure these fuses that a counterbalancing torque is applied to the screw on which the nut is tightened. Failure to do so could result in damage to the busbars, thyristor module and fuse. A hex headed screw (1) is fitted inboard, and a hex socket screw (7) nearest the line connections

Remove the old fuse by slackening the retaining nuts (2) and pulling the fuse (6) forward through the slots in the busbar. Ensure that a counterbalancing torque is applied as above. Remove the socket / hex head set screws from the fuse and screw them hand tight into the new fuse (with nuts and washers fitted as before), while holding the fuse in the hand. Slacken off the M8 hex head screws (8) which hold the line cable support pillars to the support

plate, to allow the line busbar to tighten up correctly against the new fuse, which may be of slightly different thickness. Slide the fuse into the slots in the busbars. Ensure that the 50mm load spreading washers (5) are fitted, and that they are seated flat against the busbars (not held off by the bend radius in the busbar) and the busbars are seated properly against the fuse. Ensure the fuse is inserted to the same depth in each busbar. Retighten the fuse nuts, applying a counterbalancing torque - recommended torque 25Nm. Retighten the cable support pillar screws (8), first ensuring that the pillars are square against the busbar.

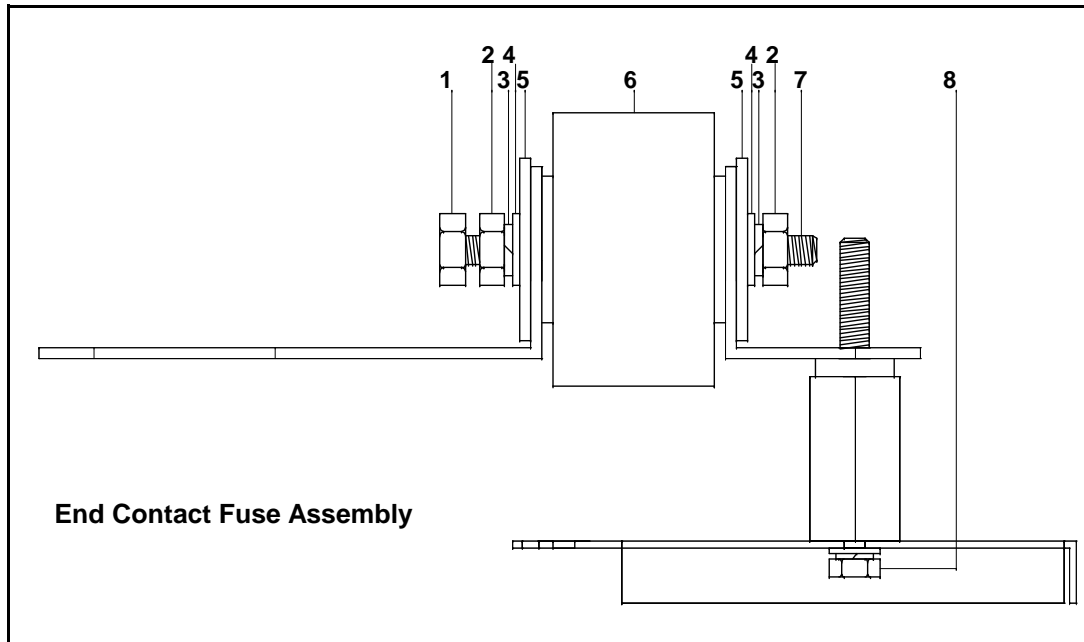

	1 Hex head screw	2 Nuts	3 Spring Washer	4 Plain Washer	5 Pressure Washer	7 Socket head screw
600A	M10x30mm	M10	M10	M10	50mm OD / 12.5mm I/D	M10x35mm
800A	M12x35mm	M12	M12	Not fitted	50mm OD / 12.5mm I/D	M12x35mm

M = ISO Metric Coarse.

INSTALLATION

GENERAL REQUIREMENTS

The following notes are a guide to ensuring sound system design, and compliance with the requirements of the European Low Voltage Directive and other international standards.

The stacks should be installed in a cabinet requiring a tool to gain access, and access should be restricted to suitably trained and qualified personnel. Provision should be made to exclude conductive pollution (eg graphite dust) from the cabinet, and to avoid condensation.

Caledon thyristor stacks are designed with an impulse withstand voltage of 4kV. This meets the requirements of IEC and European standards for installation category 3, and supply voltage (line to earth) up to 300V (AC RMS). This corresponds to 520V line to line on most distribution systems, in which the supply transformer is star connected with earthed star point. This does not preclude the use of the stacks in higher voltage systems (provided the thyristor devices are suitably rated), but precautions may be necessary (eg surge arrestors) to limit the expected impulse voltage level, if systems compliance with the above standards is required.

All stacks in the SRC range incorporate integral semiconductor fuses. These are intended to provide short circuit protection for the thyristor devices, by limiting the peak half cycle surge current and total energy let through. They only provide limited protection against long term overload. The stack ratings are co-ordinated with standard HBC fuse values, and the supply cables should be protected with gL fuses or circuit breakers of current rating the same as, or lower than the stack. All the stacks with fan cooling also incorporate automatically resetting thermal cut outs, which monitor the temperature of the heatsink, and ensure that it does not rise to an unsafe level.

The stacks must be fitted with a protective earth conductor, and the earth connection must be capable of carrying the prospective fault current for the main load circuit until the protective fuse blows. The main reason for this is to protect against short circuit to ground which might occur in one of the semiconductor modules, should the internal structure rupture under severe fault conditions. Provided the correct semiconductor fuses are fitted, which limit the maximum energy let-through under short circuit conditions, a short cable of 25mm² cross section connecting between the stack earth stud and the chassis plate will provide an adequate local earth. Care must be taken to ensure that the panel in which the stack is installed is adequately earthed, with an earth loop impedance less than 0.03Ω (400V, 800A system), and taking account of local regulations.

The stacks are rated for a maximum ambient operating temperature of 50°C (45°C for 800A unit). This refers to the ambient air temperature entering the heatsinks at the base of the stack. The design of an installation must however take into account the ratings of cables and other switchgear within the cabinet. Elevated temperatures also shorten the life of some electronic components, notably electrolytic capacitors, which dry out. A major cause of elevated temperatures in a cabinet containing thyristor stacks is the power dissipated by the thyristor devices, which may be approximated in watts as 1.5 x (RMS current) x (Number of controlled lines). The exhaust air temperature from the stack will be higher than ambient by up to 20°C. It is not good practice to mount other items of control gear directly in the exhaust airflow. In particular the current carrying capability of fuses or circuit breakers will be significantly reduced if this is done. A tidy solution is to mount circuit breakers or fuses supplying the stack on a sub-chassis mounted forward from the main chassis on which the stack is mounted. The exhaust air then passes behind these components. Thyristor stacks should not be mounted one above the other, as this will significantly derate the upper unit, which, for rating purposes will be operating in an ambient equal to the exhaust air temperature of the lower unit. Heat from the thyristors, together with that dissipated by the semiconductor fuses will also raise the temperature of the stack busbars to which outgoing cables are connected, and high temperature cables should be used. The cross-section of the cables and their ventilation will influence the temperature of the connection studs, and the guide in the wiring section of this manual shows recommended cross sections.

Consideration must be given to fault conditions. In particular a short circuited thyristor could result in loss of control of the load current. If this could cause a dangerous temperature to arise in the controlled load, then an independent means of monitoring and switching off the current should be provided. This could take the form of an independent over-temperature controller switching a contactor or under voltage release on a circuit breaker fitted in the main supply lines (see figure 4 for example). Contacts should be arranged to de-energise in the alarm (over temperature) state. European standard EN 60519-2 Safety in electroheat installations, part 2: Particular requirements for resistance heating equipment, para 13.3 requires independent protection of electronic heating controllers and frequently operated heating control contactors, where temperature rise in the load could otherwise be excessive under fault conditions.

Independent provision for electrical isolation of the power and signal circuits must be provided.

MOUNTING

The stack must be mounted vertically, with the fan at the bottom of the unit. Allow a minimum of 100mm above and below the stack body. to allow free airflow. Do not mount stacks one above the other. The stacks are designed to be mounted closely side by side in multi-zone applications. We recommend a minimum gap between units of 15mm.

The mounting arrangement is shown in figure 2. Screw the upper and lower mounting brackets (1 and 2) to the mounting plate using M6 x 16mm screws or similar (1 and 2-phase units), M8 x 20mm screws (3-phase units) and plain washers, but do not fully tighten. (Suitable holes should be drilled and tapped in the mounting plate, dimensions in figure 1). Hook the stack over the lower mounting bracket, and raise the upper mounting bracket to the limit allowed by the slotted holes so that the stack may be installed against the mounting plate and the bracket hooked down over it. Tighten up first the screws on the top bracket, and then the lower bracket.

COVER REMOVAL AND REPLACEMENT

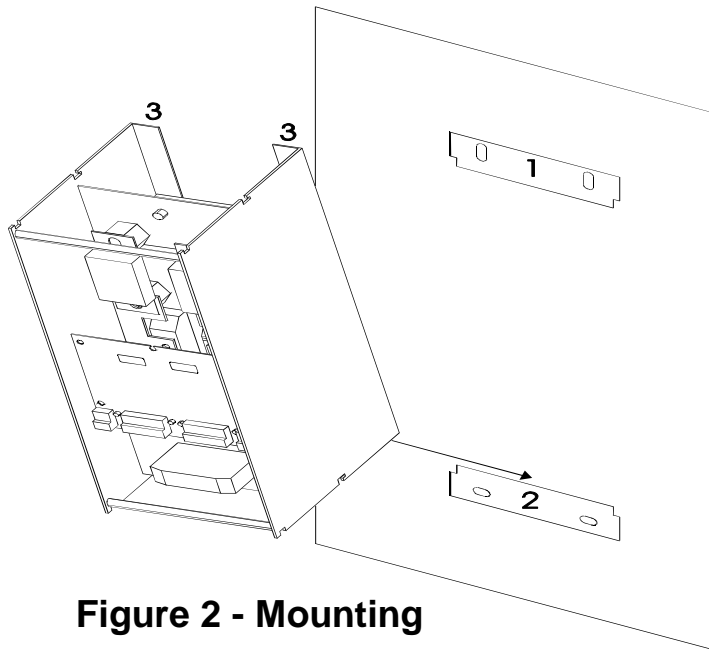

Figure 2 - Mounting

A 3-part clear polycarbonate cover is provided. The top and bottom cable entry covers are held in place by the front cover.

To remove the covers:-

- 1 Grip the front cover at the top centre and pull forward. The cover will unclip.
- 2 The top and bottom cover plates are now free to be lifted off.

Note: On units built from January 2004 on, the front cover is also attached by screws which must be removed first.

To replace the covers

- 1 Line and load cables must be fed through the holes provided in the top and bottom covers. The top cover is provided with an additional slot for the earth cable. The bottom cover has a slot for the control cables.
- 2 Slide the ears on the top and bottom covers into the slots in the stack sides.
- 3 Ensuring that the bottom cover is in place, hold the front cover at an approximately 30° angle to the stack, and clip the bottom hooks over the round crossbar at the bottom of the stack, trapping the bottom cover between the bar and the lip at the bottom of the front cover. Rotate the cover flush with the front of the stack and, starting with the bottom pair, use the thumbs to press home the clips onto the nylon spigots (figure 3).
- 4 Replace the fastening screws in the front cover, if provided.

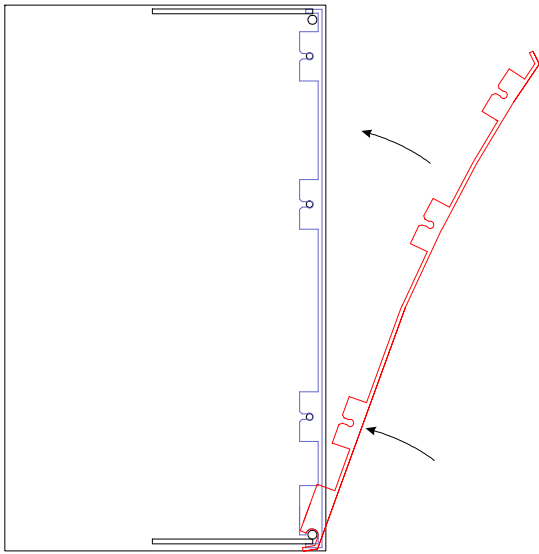

Figure 3 - Refitting the Lid

Start at the bottom and work upwards.

TYPICAL WIRING SCHEMATICS

Typical wiring schematics are shown in figure 4 and figure 5. Figure 4 shows a representative schematic for an SRC2000 stack, offering 2 line control of a 3 wire star connected 3-phase load. Figure 5 shows skeleton schemes for other stack and load types. Generally, for single phase loads, an SRC2000 stack can be considered as two completely independent single phase controllers, and an SRC3000 stack as three controllers. Using the SRC2000 offering 2-line control, three-phase loads can be connected either star or delta, but 4-wire star (with star point connected to the supply neutral) is not possible when only two lines are controlled. The SRC3000 may be used for 3-wire star or delta loads or 4-wire star. The optimum arrangement for the auxiliary lines differs between the 3-wire and 4-wire cases.

To ensure that the stack insulation is not compromised by the installation when cables associated with different circuits are grouped together, the insulation of the cables must be suitable for the voltage of the highest voltage circuit in the group.

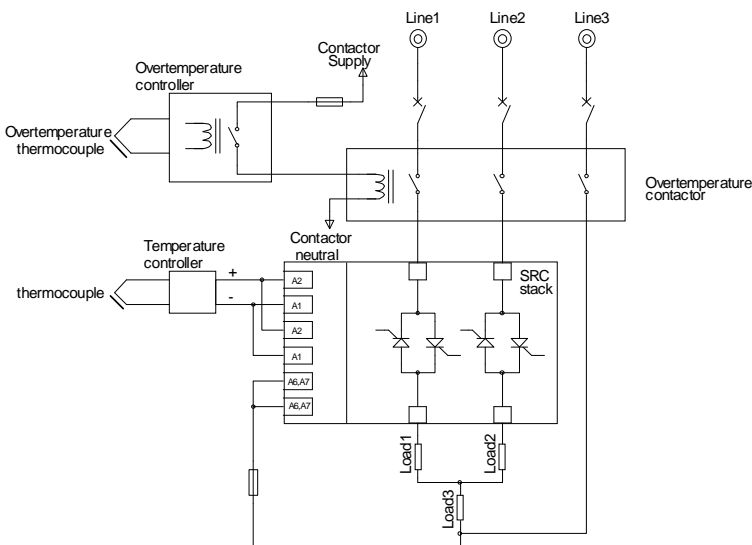
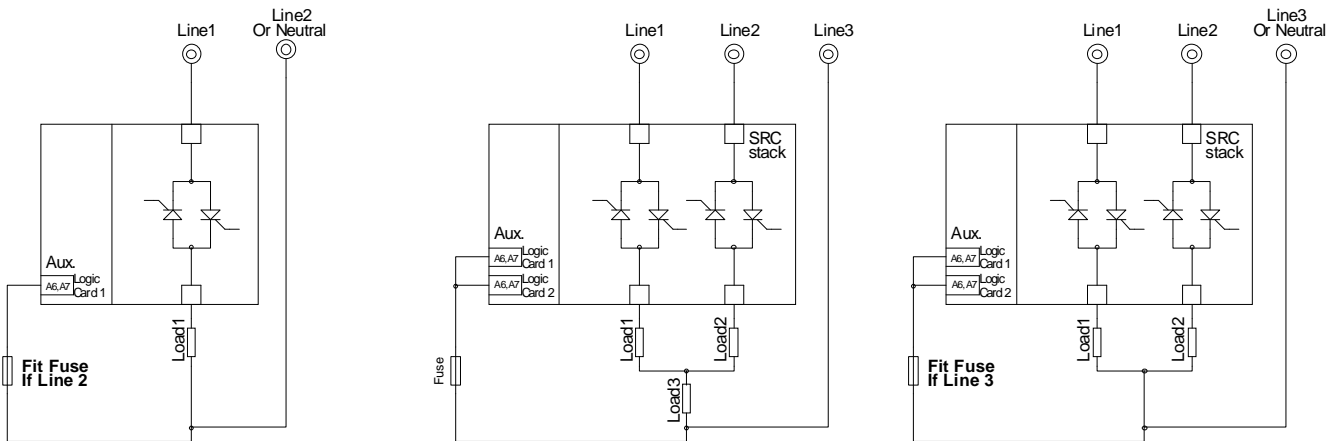

Figure 4

Representative schematic for an SRC2000 stack controlling a 3-phase 3-wire star connected load.

Figure 5 - Various Connection Schemes - Skeleton Outlines



(a) SRC1000 with single phase load

(b) SRC2000 with 3-phase 3-wire star connected load (delta also possible)

(c) SRC2000 with two single phase loads

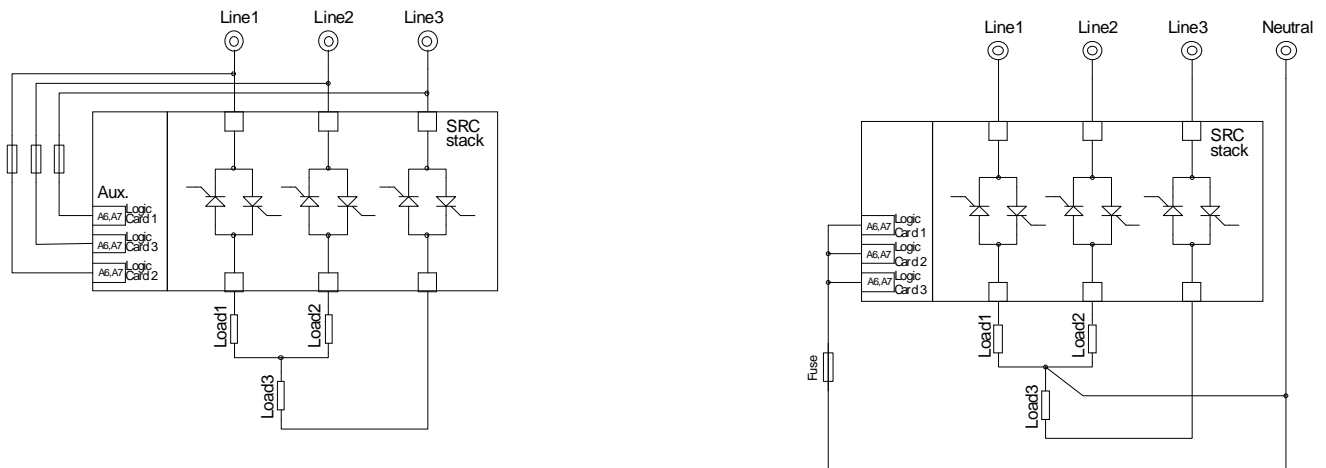

(d) SRC3000 with 3-phase 3 wire star connected load (delta also possible)

(e) SRC3000 with 3-phase 4-wire star connected load

RECOMMENDED POWER CABLE SIZES

The following is a guide only, as installation conditions will vary. A maximum control cabinet temperature of 45°C has been assumed, with cables routed in free air in the immediate vicinity of the stack, and passing into trunking in groups of three. The cable protective fuse or circuit breaker rating has been assumed to be equal to the stack current rating. High temperature cable should be used, with an operating temperature of 120°C. A suitable type is Brand Rex cross linked polyolefin. The 600A and 800A units have been designed for use with two cables connected in parallel.

STACK RATING	CABLE X SECTION
315A	150mm ²
400A	150mm ²
600A	2 x 150mm ²
800A	2 x 150mm ²

POWER CABLES AND ACCESS TO THE LOAD TERMINALS

Use the guide in the previous paragraph when determining cable type and cross section. Cables should be connected using heavy duty tube type ring crimp terminals. The stud diameter is 10mm on the 315A and 400A

units, 12mm on the 600A and 800A units.. Do not forget to feed the line and load cables through the holes in the polycarbonate covers before attaching to the terminals!

Two versions of these stacks have been supplied.

On units delivered prior to January 2004 access to the 'Load' connection studs is gained by first hinging up the polycarbonate shelf that supports the control cards. Simply pull it forward at the bottom, using a finger behind the shelf at either side. It will unclip, and when raised sufficiently, lock in the raised position. Simply push it back and reclip it when the cables are attached.

On units delivered after January 2004 the load terminals will be immediately accessible, unless the analogue input / relay option card is fitted. If this card is fitted it may be removed temporarily by loosening (but not removing) the two M5 cross head screws immediately above it (between it and the logic input card).

A protective earth connection of suitable cross section should be made to the stud at the top of the unit.

More information is provided under 'Installation - General Requirements'.

Note that all studs are fitted with a plain and spring washer. The recommended tightening torque is 15Nm

SIGNAL AND AUXILIARY CONNECTION TERMINALS

These connections are made direct to the printed circuit board connectors. When the stack has been specified with an analogue input card this will have been factory pre-wired to the logic inputs. All connectors are suitable for cable up to 1.5mm² cross section. Note that all connectors are unpluggable for ease of maintenance.

TERMINAL FUNCTION LIST

The following table shows the terminal functions. More detailed information is provided after the table.

Number	Function	Comment
Logic input cards. One card is fitted for each phase		
A1	Logic input -ve	
A2	Logic input +ve	
A3	No connection	
A4	Fuse / Line status +ve	Isolated NPN transistor output - collector
A5	Fuse / Line status -ve	Isolated NPN transistor output - emitter
A6 A7	Auxiliary line connection	A6 and A7 are internally commoned
A8	No connection	
A9 A10	Fan supply	Connect correct fan supply across these terminals. In 2 and 3-phase stacks the connection is to the board on the right only
Analogue input card		
B1	Line / fuse status contact N/O	Volt free contact, open in unpowered state, or absence of line supply
B2	Line / fuse status contact N/C	Volt free contact, closed in unpowered state, or absence of line supply
B3	Line / fuse status contact common	Common for contacts B1 and B2
B4	No connection	
B5 B6 B7 B8	Input signal +ve Channel 1 Input signal -ve Channel 1 Input signal +ve Channel 2 Input signal -ve Channel 2	Signal type for channel 1 selected by jumpers 2A and 2B. For channel 2 selected by 3A and 3B. 250Ω burden required across input terminals for mA inputs. Use channel 1 for single 3-phase load, channels 1 and 2 for two single phase loads.
B9 B10 B11	Supply voltage 230V Supply voltage 115V Supply voltage neutral	Connect supply between B11 and the appropriate choice of B9 or B10.

Continued on next page

<i>The following terminals are normally factory pre-wired</i>		
B12	Fuse / Line 2 status input -ve	For 2-phase applications connect B15 to A4 and B14 to A5 on the phase 1 logic card. Connect B13 to A4 and B12 to A5 on the phase 2 logic card. Ensure that jumper 1A is not made.
B13	Fuse / Line 2 status input +ve	
B14	Fuse / Line 1 status input -ve	
B15	Fuse / Line 1 status input +ve	For single phase applications connect B15 and B14 as above. Do not connect to B12 or B13. Ensure that jumper 1A is made.
B16	Logic output channel 1 +ve	For one single phase application connect B16 to A2 and B17 to A1.
B17	Logic output channel 1 -ve	
B18	Logic output channel 2 +ve	For two single phase loads or 2-line control of 3-phase loads, connect B18 to A2 and B19 to A1 on the second phase card. For 3 line control of a 3-phase load, the 3rd phase card A1 and A2 must also be wired to B19 and B18 For 2 single phase loads make Jumper 4A and break jumper 4B For a 3-phase load break jumper 4A and make jumper 4B
B19	Logic output channel 2 -ve	

AUXILIARY LINE CONNECTIONS

In addition to the main high current line and load connections, it is necessary to make auxiliary connections to the side of the load remote from the thyristor controller. The connection provides a small current for the driver circuit, and also serves to connect the integral emc suppression capacitors. Several configuration examples are given in figure 5. In 2-line (SRC2000) applications the auxiliary connection for Load 1 and Load 2 will usually be to the same point, eg the supply neutral or line 3 for two single phase loads (c) or the third line for a three phase load (b). In 3-line (SRC3000) applications the connection is normally in rotation with 3-wire loads (d) (this may be factory pre-wired), or to the neutral with 4-wire loads (e). Each auxiliary line connector has two terminals, so that a link may conveniently be run between the connectors where required. Where the auxiliary line is not the supply neutral it is desirable to fit a fuse (1A) to protect the cable against short circuit to ground.

FAN AND ANALOGUE INPUT CARD SUPPLY CONNECTION

A supply for the fans of the correct voltage, as shown on the rating plate, must be connected. The fans are thermally protected; the supply cable should be protected by a maximum 3A fuse. When an analogue input card is fitted this will normally be wired in parallel with the fan supply. The transformer on the analogue card is thermally protected, and can be fed from the same fuse as the fans.

CONTROL CABLES

It is not specifically necessary to use screened cable for the wiring of control circuits to meet the emc immunity level specified in EN 61000-6-2. We recommend that good wiring practice be followed within the control panel in which the stack is installed, taking care to avoid running signal wiring parallel to high current or switching circuits as far as is reasonably practical. If signals are sourced from outside the panel we recommend that screened cable be used outside the panel, and the screen earthed at the point of entry to the panel. This is most conveniently undertaken using special glands, but if pigtailed are used these should be earthed to the metalwork as directly as possible. If screened cable is used between the entry to the panel and the stack, then the screen should be earthed to the metalwork near the stack. Incorrect earthing of screened cables can result in worse performance than using non-screened cables.

LOGIC INPUTS

Each load has its own logic input signal. This enables two or 3 single phase loads to be controlled independently (in the SRC2000 and SRC 3000). The logic inputs are galvanically isolated from each other (isolation withstand AC 1kV RMS), allowing use in 2 and 3-zone systems with low cost temperature controllers, each having its own thermocouple and unisolated logic output. It is often important to maintain isolation under these circumstances because the thermocouples may be at different potentials due to leakage currents from the elements within the furnace.

In 3-phase applications, or in cases where 2 or 3 single phase loads are to be controlled from one controller, the logic inputs must be connected together. They may be connected in either series or parallel, to suit the drive capability of the controller. Each input appears as a 2k Ω resistor in series with a 3.5V threshold and requires a minimum drive of 6V and 1.25mA to turn it on correctly. Thus if two are connected in parallel, a minimum drive of 6V and 2.5mA is required. If they are connected in series a minimum drive of 12V and 1.25mA is required.

Examples are shown in figure 6.

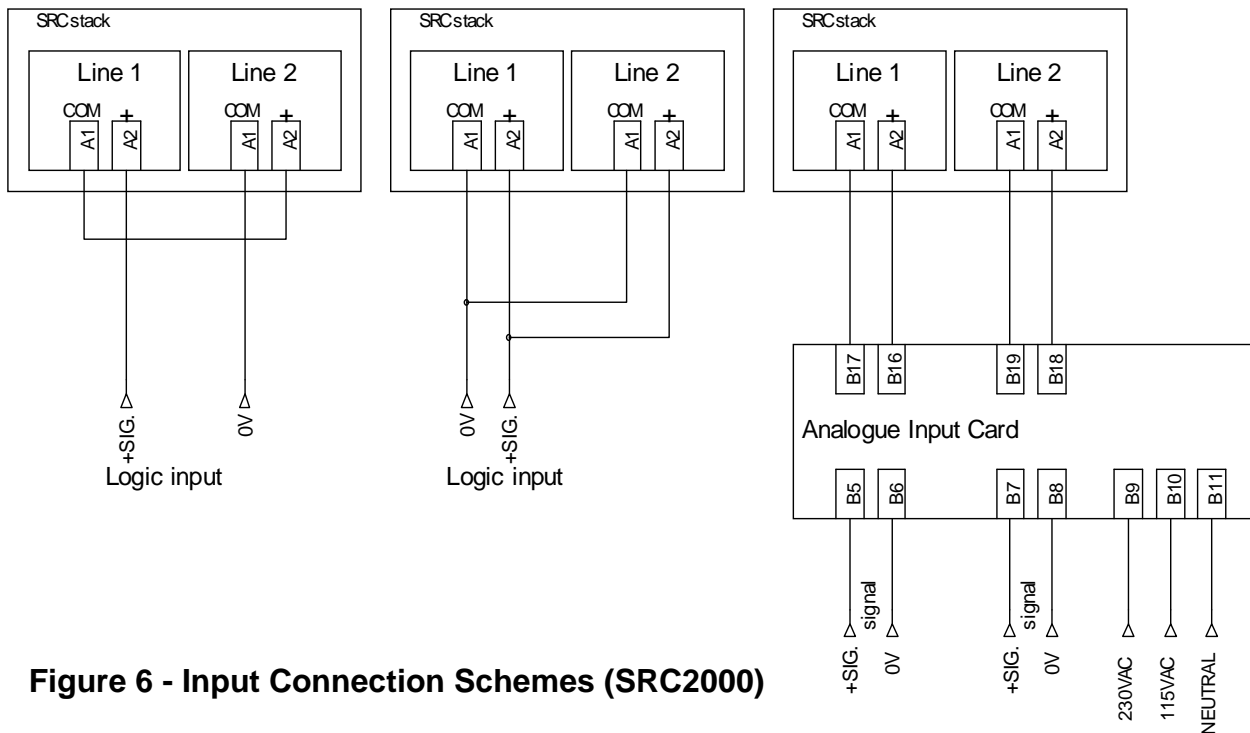

Figure 6 - Input Connection Schemes (SRC2000)

ANALOGUE INPUTS

When the optional analogue input card is specified at the time of ordering the stack, this will be pre-wired to the logic inputs. A single card can control a single 3-phase load or 2 single phase loads. A typical connection diagram is shown in figure 6. If required, two cards can be fitted in a 3-phase stack to control 3 single phase loads independently.

The analogue input signal required is determined by jumpers on the card (Fig 7):-

Figure 7

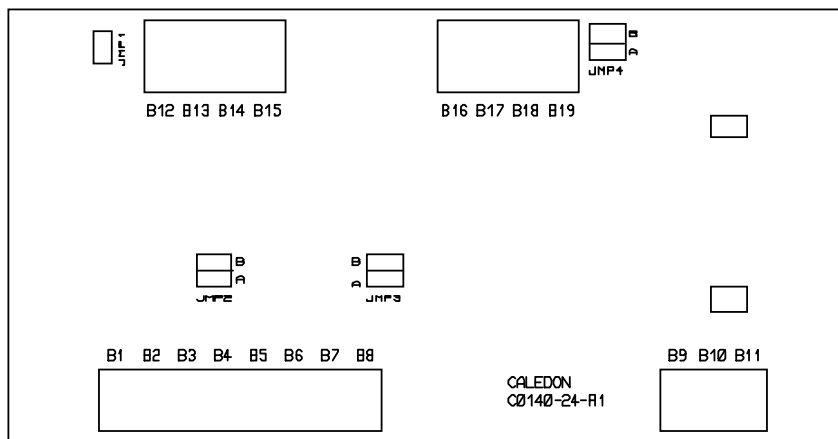

Input Signal	Channel 1		Channel 2	
	Jumper 2A	Jumper 2B	Jumper 3A	Jumper 3B
0-5V	Make	Break	Make	Break
1-5V	Break	Make	Break	Make
0-10V	Break	Break	Break	Break

For mA input signals fit a 250Ω burden resistor across the input terminals and use 0-5V for 0-20mA or 1-5V for 4-20mA.

FUSE FAILURE INDICATION AND OUTPUT SIGNAL

Each logic input card in the stack is fitted with an independent fuse monitoring circuit. The circuit monitors the presence of the supply voltage between line and the auxiliary line connected to that card. The LED marked 'fuse' is illuminated and the transistor output is on (conducting) when greater than $\frac{2}{3}$ line voltage is present (Line voltage means the rated voltage of the stack).

The transistor outputs are suitable for interfacing with 12V or 24V DC relays, or 24V DC inputs on plcs. Because the transistors are electrically isolated, and there is access to both emitter and collector, they may be wired as either pull up or pull down, and in series to provide a combined signal which turns off if either fuse fails. Examples are shown in figure 8. The transistor is zener protected, so a diode suppresser is not needed on the relay.

When an analogue input card is fitted the transistor outputs are wired in series to energise the relay fitted on the card. The relay provides a volt free changeover contact, and is energised if all line voltages are present, and de-energises if any line voltage is not present.

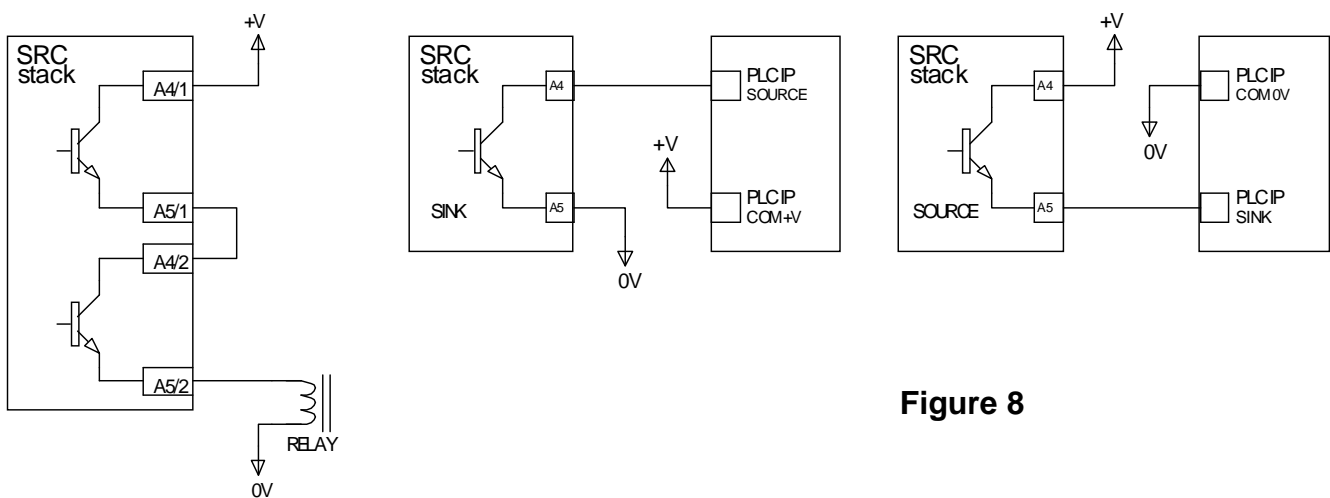

Figure 8

BRIEF NOTES ON OPERATION

COVER

For safety reasons the stack should not be operated with the clear polycarbonate covers removed. Additionally, the fans direct a proportion of their airflow over the control card and semiconductor fuses, and this cooling action, particularly of the fuses, will be impaired if the cover is removed. For information on removing or replacing the covers see under 'Installation – cover removal and replacement'.

DEMAND SIGNAL

The stack operates in burst fire mode; ie the load current is either on or off. The start of each burst is synchronised to the supply, with zero voltage switch on. The LED(s) marked 'Demand' on the main logic input PCB(s) flash on and off to indicate when the control signal is demanding power or not. Note that this indication does not necessarily mean that load current is flowing (eg if there is a blown fuse)

LOGIC CONTROL SIGNAL

The input signal is a voltage which switches the stack on when applied. The maximum input voltage is 30V; When the signal is <2V the stack is off; >6V the stack is on. The cycle period is set by the switching rate of the signal from the controller.

ANALOGUE CONTROL SIGNAL

The analogue input card converts an analogue signal to logic pulses, and a 50% duty cycle is set when the input is at 50% (2.5V for 0-5V input, 3V for 1-5V input, 5V for 0-10V input). The stack is fully off with an input of 4% or less, and fully on with an input of 96% or more. At 50% duty cycle, one cycle period is approximately 0.75 seconds. At duty cycles other than 50%, the cycle period becomes progressively longer as the duty cycle increases or

decreases (to a maximum of approximately 8 seconds). This enables the average power delivered on the cycle to be modulated over a wide range without having unduly short 'on' or 'off' periods.

FUSE FAILURE INDICATION

The fuse status LEDs will be illuminated when the main supply to the stack is present. They extinguish when a supply is lost (see under fault finding), and will thus not be lit if the distribution fuses fail or if an over-temperature contactor has opened. On 2-phase and 3-phase models exactly which LEDs extinguish in the event of a fault depends on the way the stack is connected. The LED on each card indicates the presence of the correct voltage between the line connection associated with the card and the auxiliary line connection to that card. For the stack to be operating correctly the LEDs on all the cards must be illuminated.

FAULT FINDING

Before attempting to rectify a fault on the unit, it is most important that the section headed **SAFETY INFORMATION** should be read and noted.

The following is a guide to first line fault finding.

Symptom	Possible Cause
Driver card Demand LED does not light when logic signal is high	Signal not present, or too small, or wired with the wrong polarity. The stack heatsink is over-temperature – check that fan is running.
Load current does not flow when the input demand LED is on.	The line supply is not present, or the semiconductor fuse has blown, or the auxiliary line connection is not made correctly, or a fuse in the auxiliary line supply has blown. The fuse status LEDs will not be lit
The fuse status LEDs are not lit	<p>SRC1000</p> <p>The line supply is missing , or the semiconductor fuse is blown, or the auxiliary line connection is not made, or the auxiliary line supply is missing.</p> <p>SRC2000</p> <p>If the line 1 LED is lit but the line 2 LED is not then Line 2 fuse is blown or line 2 is missing.</p> <p>If the line 2 LED is lit but the line 1 LED is not then line 1 fuse is blown or line 1 is missing.</p> <p>If neither LED is lit then the auxiliary line connection is not made, or the auxiliary line supply is missing, or fuses on both line 1 and line 2 are blown.</p> <p>SRC3000</p> <p><i>note that the operation of the LEDs will depend on exactly how the auxiliary line connections have been wired.</i></p> <p>3-wire and 6-wire connection</p> <p>If the line 1 LED is lit but the line 2 and 3 LEDs are not lit then line 3 is missing</p> <p>If the line 2 LED is lit but the line 1 and line 3 LEDs are not lit then line 1 is missing</p> <p>If the line 3 LED is lit but the line 1 and line 2 LEDs are not lit then line 2 is missing</p> <p>4-wire connection</p> <p>The line corresponding to any unlit LED is missing, or the auxiliary line connection has not been wired to the neutral.</p>
Load current does not switch off when the input LED is extinguished.	There is a fault on the driver card, or the thyristor module is short circuit.
The LED on the analogue voltage input card does not light.	The auxiliary supply to the card is missing.