



3-Phase Thyristor Controller for operation in single cycle burst fire and standard burst fire modes

Type CB17



Features / Benefits

- ◆ Universal power supply.
- ◆ Potentiometer for manual control of load power when required.
- ◆ May be used with 3-line control or 2-line control of a 3-phase load.
- ◆ Advanced patented (UK patent Number 2403855B) single cycle control algorithm for use with 3-wire load connection, minimises harmonics, and eliminates DC components. Maintains accurate load balance when used with 2-line control.
- ◆ DIN rail mounted version also available

Brief Description

This controller is available in versions for panel mounting or mounting on T35 DIN rail. It is primarily intended for the control of 3-phase loads in single cycle burst fire mode. It is designed to accept a standard analogue control signal from a temperature controller and its output is a standard logic signal. The output may be used with solid state relays, thyristor stacks which accept a 'logic' input signal, or in conjunction with associated trigger modules to drive thyristor gates directly. In all cases the firing circuit must be designed for zero voltage switch on.

The controller may also be used to control single phase loads, and can be operated in standard burst fire mode, in which case the cycle time may be adjusted by means of a potentiometer (accessible at the rear of the panel mounted instrument).

Applications

Single cycle burst fire control is used when minimum fluctuation in heater element temperature between bursts is required, without the high harmonic distortion associated with phase angle control; eg for near infrared heating, or when using silicon carbide hot rods. It is also useful if a system is powered by a gen-set, when standard burst fire control can result in speed instability.

The following are examples of applications to which this versatile controller is suited:-

- 1 To interface between an analogue control signal from a temperature controller and logic input thyristor stacks or solid state relays.
- 2 To manually control the output power of logic input thyristor stacks or solid state relays, using burst fire control or single cycle burst fire control.
- 3 To provide an auto / manual function in a temperature control loop, with manual control by means of the front panel potentiometer.

The front panel potentiometer may be used to perform the following functions:-

- 1 To manually control the power delivered by the thyristors.
- 2 To provide a simple means of limiting the maximum power, when used in conjunction with a temperature controller.
- 3 To proportion the analogue input signal from a temperature controller (see options). This feature can be used to balance the heat input to multiple heating zones controlled by one temperature controller. (One instrument required for each zone).

Specifications

Supply voltage	95V to 255V universal power supply, internally protected with non-resettable thermal cut out	
Power consumption	3VA	
Ambient temperature	0-55°C	
Input signal	0-5V, 0-10V, 1-5V, 2-10V, 0-20mA, 4-20mA, link selectable	
Output signal	Logic signal, 10V minimum voltage, 20mA maximum current, suitable for driving up to three Caledon thyristor trigger modules, or a 3-phase Caledon thyristor stack. The instrument may also be used to drive solid state relays, provided that the drive requirements are met.	
Manual Operation	By means of front panel potentiometer. Manual operation selected by rear panel input	
Burst fire Cycle Time	Minimum 0.3s, maximum 20s at 50% duty cycle.	
Front panel indicators	Green LED -	power on
	Red LED -	output operating
	Yellow LED -	manual operation selected
Safety Standards	Complies with European Low Voltage Directive and major international standards.	
EMC Standards	Complies with the European EMC Directive for operation in an industrial environment	

The following standards have been applied in whole or in part in the design of this instrument; EN61010-1, EN61000-6-2, EN 50 081 part 2

Ordering Information

The following information is required when ordering an instrument:-

Instrument Type	CB17-P	Panel Mounted.
	CB17-D	DIN Rail Mounted.

Optional Auto / Manual selection push button if required (panel mounted instruments only).

Optional version for proportioning the analogue input if required.

Terminal Connections

Connections are made to a removable terminal plug, which will accept wires up to 1.5mm² cross section. The use of screened cable is not necessary for control signal wiring within a panel, but normal precautions should be taken to keep signal wiring away from power cables, and in particular to avoid running signal cables parallel to power cables. See also the notes on configuration jumper settings, supply connection and synchronisation, and the typical wiring scheme.

Terminal Number	Function	Notes
1	Supply Live	95V to 255V, 50 or 60Hz AC. For correct operation the supply must be in phase with the load supply. See diagram and notes on page 4.
2	Supply Neutral	
3	No internal connection	Do not connect anything to this terminal.
4	Functional earth	This terminal may be earthed to nearby metalwork to give enhanced EMC immunity. The instrument does not require a safety earth connection.
5	Input signal + from temperature controller	Signal type selected by links-see below
6	Input signal - (common 0V line)	
7	Auto / manual select	Link terminal 7 to terminal 8 for manual operation by front panel potentiometer
8	(common 0V line)	
9	Output logic signal +	Wire to up to 3 thyristor trigger module / logic inputs in parallel. The single output controls all thyristor pairs (or solid state relays) in a 3-phase system.
10	Output logic signal - (common 0V line)	

Configuration Jumper Selections

There are two groups of jumpers.

In the case of the panel mounted instrument they are accessible by removing the rear cover of the instrument (remove the rear connector and undo 4 screws). The printed circuit card may be partially retracted to improve access. Take care to ensure that the front panel LEDs align correctly in their slot when pushing the board back into place.

The jumpers are directly accessible from the front of the DIN rail mounted instrument.

Jumper Number		Function	Notes
Jumper group 1 - Input signal selection for auto operation (Analogue signal from temperature controller)			
1:1	Unlinked	Voltage input	Select the signal type. When linked, connects a 250 ohm resistor across the input.
	Linked	Current input	
1:2	Unlinked	0-5V, 1-5V, 0-20mA, 4-20mA	Select the signal span
	Linked	0-10V, 2-10V	
1:3	Unlinked	No offset (0-5V, 0-20mA, etc)	Select the signal zero offset
	Linked	With offset (1-5V, 4-20mA etc)	
Jumper Group 2			
2:1	Unlinked	Single cycle operation	Select the control mode
	Linked	Standard burst fire operation	
2:2*	Unlinked	Controller power supply in phase with line to line supply	Normal operation
	Linked	Controller power supply in phase with line to neutral	Cannot be used with 2-line control.
2:3*	Unlinked	Load connection for 2-line control. Load star or delta connected.	Only 2 of the 3 lines are controlled. The third is directly connected.
	Linked	Load connection for 3 line control	All 3 lines are controlled by thyristors.
2:4*	Unlinked	3-line control, 3-wire load connection (star or delta).	This link is only operative if 2:3 is linked. Must then match the load connection.
	Linked	3-line control, 4-wire star load connection	
2:5	Unlinked	In auto mode the front panel potentiometer has no function	In manual mode the potentiometer controls the output power independent of the input control signal. Applies to software versions CB03E5Rx (where x is the issue number). Standard from 2005. Software version CB03E1Rx available as an option offers proportioning of the input signal by the front panel potentiometer when in manual mode. This is useful if it is desired to balance multiple heating zones.
	Linked	In auto mode the front panel potentiometer sets an upper limit on the input control signal	
2:6	Unlinked	No function	Normally should not be linked. See following notes.
	Linked	Logic signal not synchronised to the mains frequency	

* For single phase operation, where the supply to the controller is in phase with the supply to the load, fit jumpers 2:2, 2:3 and 2:4

Safety and Regulatory Considerations

The controller must be wired in accordance with electrical standards applicable in the country of installation.

When controlling heating loads it is important to consider the effects of loss of control due to a fault; eg the heating power being turned fully on. If this could result in a dangerous situation then independent means of monitoring the load and removing power should be fitted. This is a requirement of international standards.

Control of thyristors in single cycle mode gives rise to harmonic currents and electrical noise, and it should be ascertained that these fall within acceptable limits for the application. Further information on harmonics is available on request.

Burst Fire and Single Cycle Burst Fire Control

Burst fire control is a method of controlling the load power by switching the current on and off. The current is on for a number of supply cycles and off for a number of cycles. The load power is varied by varying the ratio of on time to off time. In burst fire mode the shortest on-off period offered by this controller is 0.3s at 50% duty cycle (half power), corresponding to approximately 8 supply cycles on and 8 cycles off at 50Hz.

Single cycle burst fire control is the fastest type of burst fire control possible. At 50% duty cycle (half power) one supply cycle on is followed by one off. Above 50% power only one supply cycle is allowed to be off before

another on cycle. Any number of on cycles may follow each other consecutively. Below 50% power only one supply cycle is allowed to be on before another off cycle. Any number of off cycles may follow each other consecutively. The average ratio of on to off cycles is controlled to obtain the required average load power. The averaging is performed over between 50 and 100 cycles, enabling power resolution better than 2%. Representative diagrams of the current waveforms are given on pages 6 and 7.

Supply Connection and Synchronisation

Synchronised or unsynchronised operation may be selected by means of jumper 2:6.

Normal (synchronised) Operation

To obtain optimum results with the controller, particularly in single cycle mode, synchronised operation is essential.

The controller derives its synchronisation to the mains power supply via its power supply connection. The power supply to the controller must therefore be synchronous with the main load supply, and have the correct phase relationship.

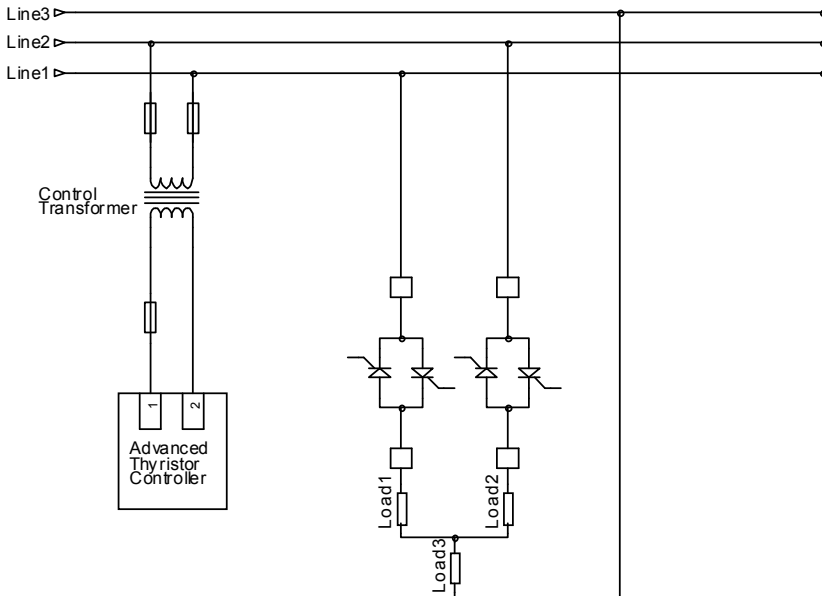

It is most important that the jumper settings in the controller match the control and load type, otherwise incorrect firing of the thyristors may occur, potentially leading to load unbalance and DC components in the load current.

With 2-line thyristor control of the load (heater) current the controller power supply must be in phase with the voltage across the two controlled lines, as in the adjacent diagram. The control transformer is required to match the operating voltage of the controller to the line to line supply voltage.

With 3-line control the controller power supply may be in phase with the voltage across any two lines, fed via a control transformer as with 2-line control, or if jumper 2:2 is linked, in phase with the voltage between any line and neutral (which is 30° shifted), potentially enabling connection without a transformer (for example on a 400 / 230V supply, but not on a 480 / 277V supply, because the line to neutral voltage is too high for the controller).

Supply connection - 2-line control, 3-phase 3-wire load

The control transformer may be used to supply other control gear in the panel. A transformer smaller than 100VA is not recommended, as this may give rise to phase shifts which could upset the synchronisation of the controller. The fuse in series with the controller is for cable protection, and typically 5A or 6A gG. The controller is internally protected. The actual phase rotation is immaterial.

For single phase operation, where the supply to the controller is in phase with the supply to the load, fit jumpers 2:2, 2:3 and 2:4

Unsynchronised Operation (Jumper 2:6 linked)

It is possible under certain circumstances to operate the controller without synchronisation to the mains supply. In particular this mode of operation will have no adverse affect if operation in standard burst fire mode is chosen.

With single cycle operation and 3-line control, the load current waveforms will be less well defined, and some half cycle pulses will occur.

Single cycle operation with 2-line control can result in severe load unbalance, and is not generally satisfactory.

Unsynchronised operation may be chosen in standard burst fire mode for simplicity, avoiding the need to check the controller supply. It might be chosen for single cycle control if it is suspected that the controller is incorrectly synchronised due to a phase error in its supply, or if noise on the supply is causing the controller to have difficulty synchronising. If this is the case the brightness of the green 'power on' lamp will be observed to be blinking. (The LED also blinks immediately after power up, or after changes are made to the configuration links).

Dimensions and Mounting

Panel Mounted Version

Panel cut out 91.5 x 91.5 mm, ± 0.5 mm

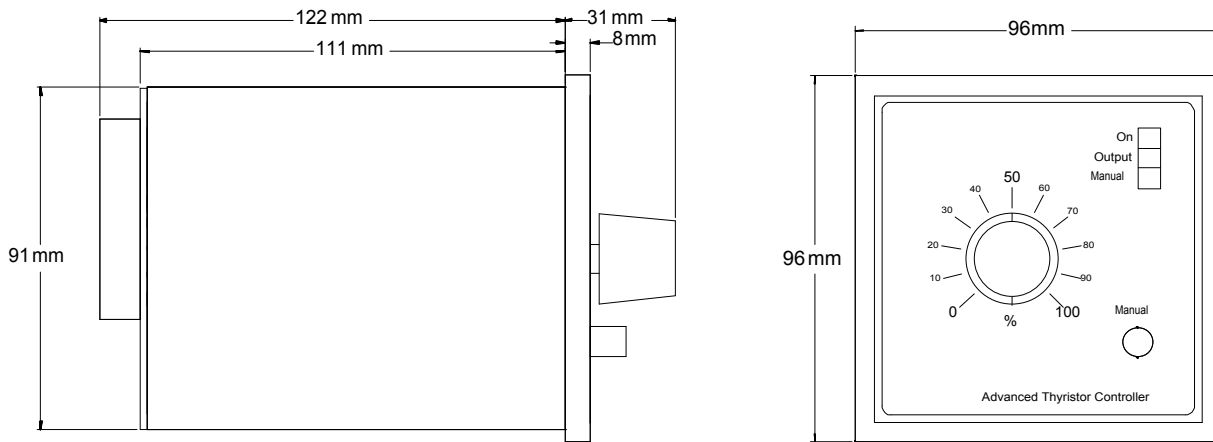

DIN Rail Mounted Version

The DIN rail mounted version is housed in a clear polycarbonate box, and provides the same facilities as the panel mounted version.

The instrument is designed for mounting on symmetrical 35mm DIN rail. Hold the instrument at an angle to the DIN rail and clip the 'hockey stick' arm under one side of the rail. Rotate the module to clip the hook under the other side of the rail. Adjust the module up / down so that it is hooked securely on both sides of the rail.

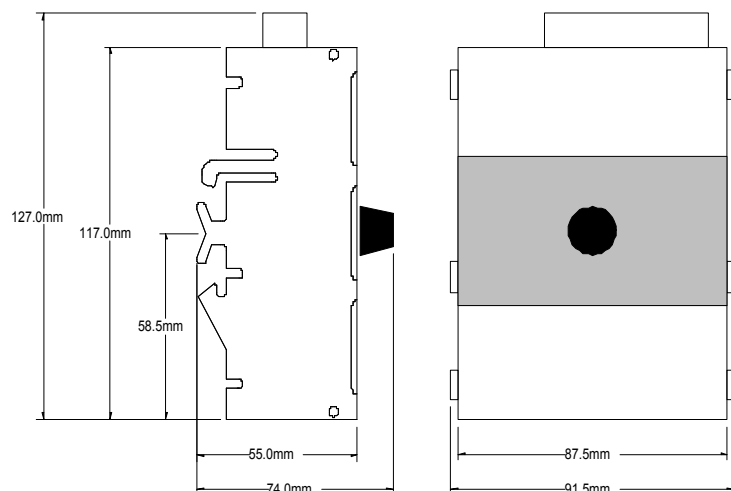

The following diagrams show representations of current waveforms for burst fire and single cycle burst fire operation. The heavily outlined portion of the sinusoidal train indicates when the thyristors are switched on, and the lighter portion indicates when they are off. The waveforms show zero voltage (and thus current) switch on, and zero current switch off, and are the waveforms obtained in single phase operation, which are sinusoidal.

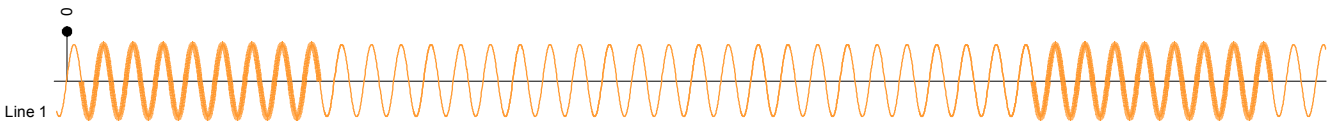

Standard burst fire, 25% power

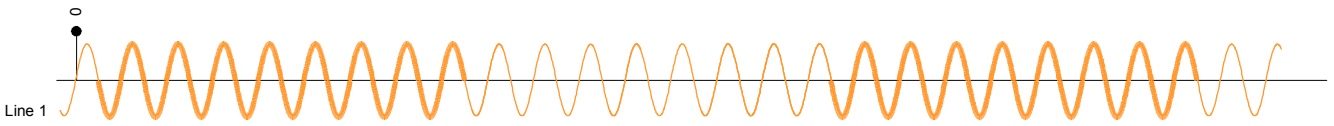

Standard burst fire, 50% power

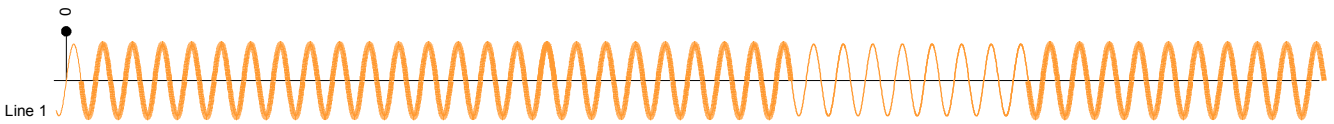

Standard burst fire, 75% power

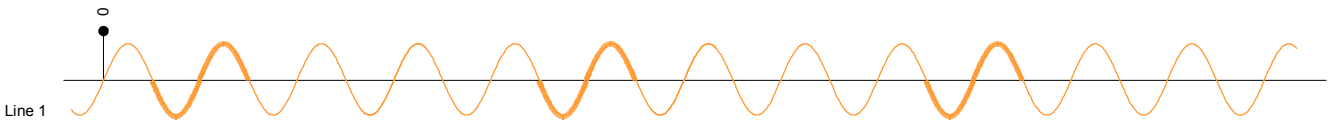

Single cycle burst fire, 25% power

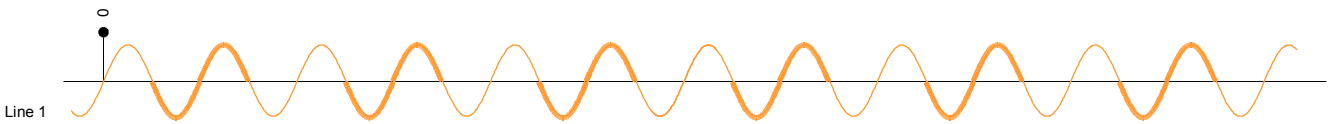

Single cycle burst fire, 50% power

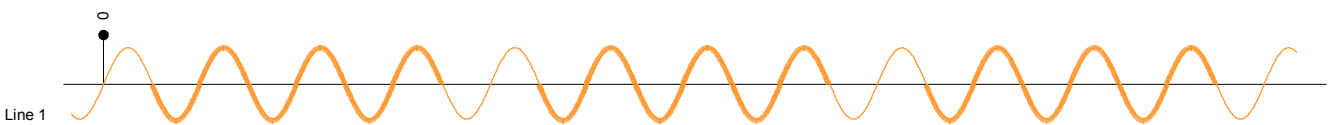

Single cycle burst fire, 75% power

The following diagrams show current waveforms for single cycle control in 3-phase systems at approximately 50% power (1 cycle on followed by 1 cycle off). In 3-wire systems the waveforms are no longer true sine waves. The controller ensures that the average current on all 3 lines is the same and that there are no DC components. In a 4-wire system the line waveforms are sinusoidal, but this apparent advantage neglects the fact that the neutral current is far from sinusoidal. The rather oddly shaped wavelshapes are also obtained in standard burst fire mode at the beginning and end of the burst.

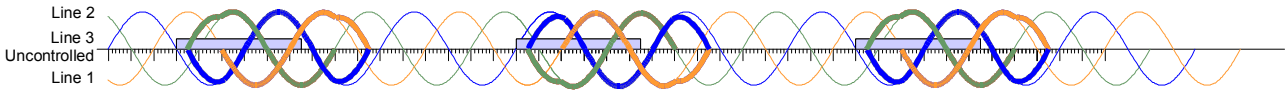

3-wire system, 2 line control

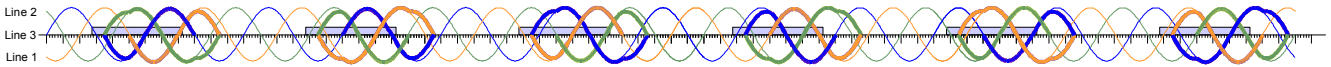

3-wire system, 3 line control

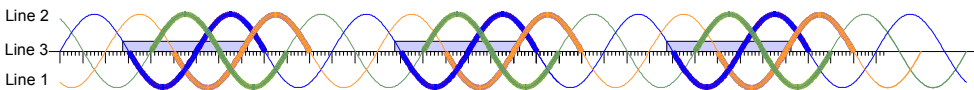

4-wire system, 3 line control

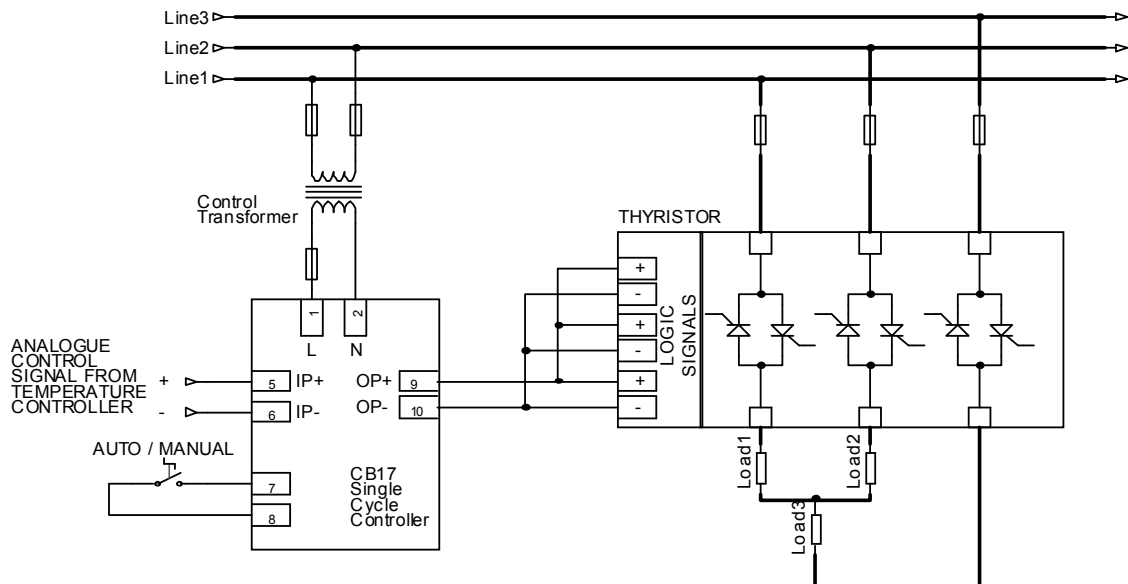

Representative wiring schematic, showing operation in a 3-phase 3-wire system with 3-line control. The thyristor stack uses one logic control input for each of the 3 lines, wired in parallel to the CB17 controller output, and provides zero voltage switch on.